

An aerial photograph of an industrial or maritime facility. In the foreground, a large white building with a dark grey roof is visible. To its right, there are several stacks of buoys in bright green and orange colors. In the background, there is a parking lot with several cars, a smaller white building with a red roof, and a large body of water. The sky is clear and blue.

SeaHow[®]

by MeriTaito

Buoy Product Catalogue

March 2018

Polyethylene Buoys

since 1976

SeaHow[®]
by MeriTaito

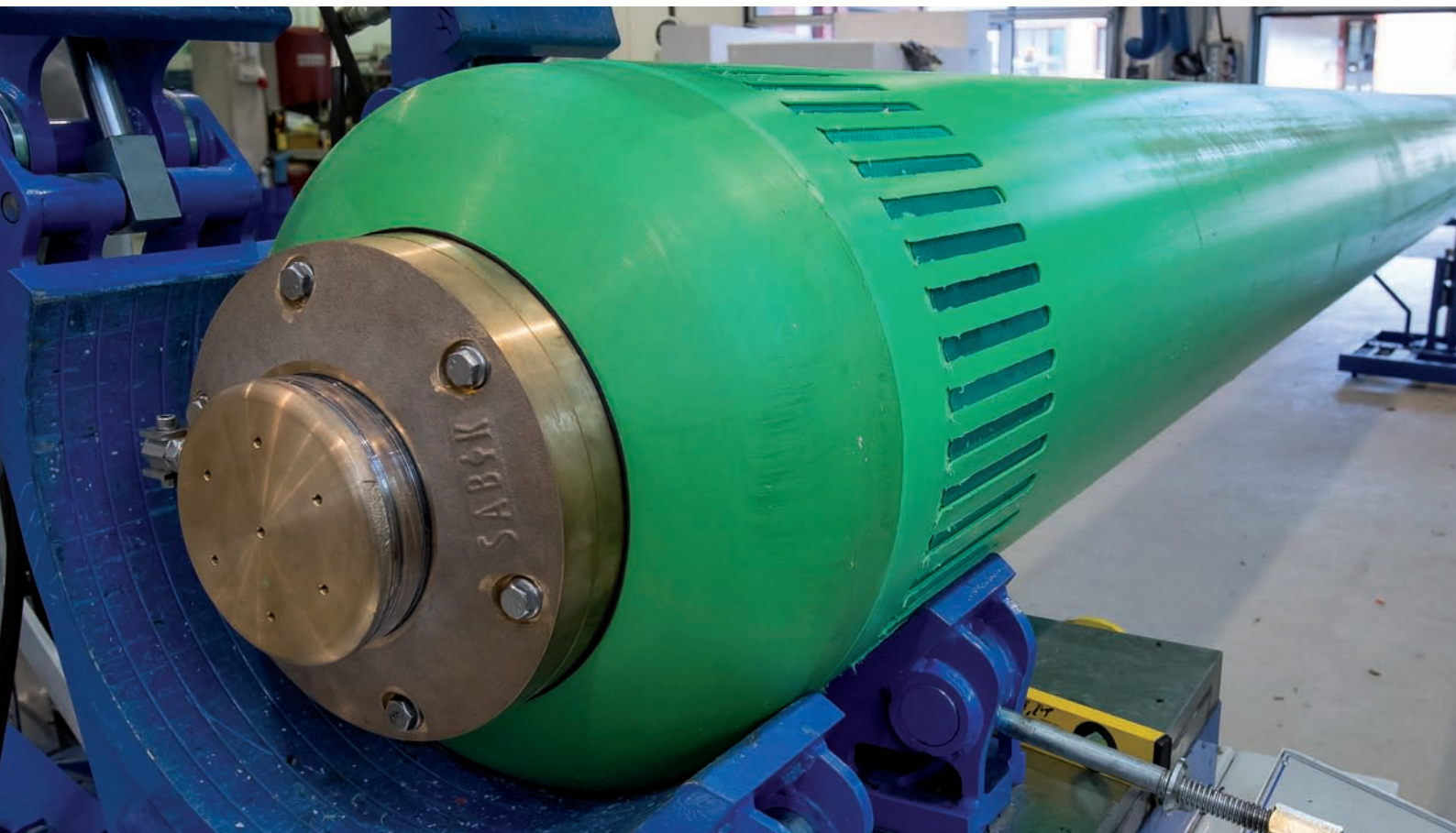

For the sustainable use of sea and inland water areas

SeaHow provides high-quality expert services and intelligent solutions that support the sustainable use of sea and inland water areas.

SeaHow is the brand name of Meritaito Ltd, which is the leading Finnish marine survey service and infrastructure management company. Meritaito Ltd is a 100% Finnish state-owned company.

The company has decades of experience in a comprehensive range of services: maintenance of waterways, use and maintenance of canals, hydrographic surveying services, oil spill response, hydraulic engineering, waterway design and manufacturing of aids to navigation.

Together with its partners SeaHow has developed a unique set of products and solutions for public and private customers who operate on shore or at sea.

Content

Polyethylene Buoys , for cost-efficiency.....	4
Smart Buoy Concept , more than just an AtoN.....	6
Offshore Buoy , VPU800.....	8
Coastal Buoy , VPU500.....	10
Coastal Buoy Shallow , VPU500/800.....	12
Port Buoy , VPU400.....	14
Marine Spar , EJ225.....	16
Boating Spar , VEP160/225.....	18
River Buoy , VPC400/800.....	20
Ice Buoy Maxi , PV800.....	22
Ice Buoy Medium , SVV500.....	24
Beacon Tower , TM500/TM800.....	26



International Sales Partners

HQ in FINLAND

Meritaito Ltd
Seppo Virtanen
seppo.virtanen@seahow.fi

SWEDEN

Rotationsplast Ab
Mattias Berntsen
mattias.berntsen@rotationsplast.se

BENELUX

Nautikaris
Sander Karis
sander@nautikaris.com

POLAND

Escort Ltd
Arkadiusz Markowski
arek.m@escort.com.pl

RUSSIA

Sabik Russia
Evgeny Nabatov
evgeny.nabatov@sabik-marine.com

MIDDLE EAST

Blue Technology General Trading
Elfatih Salahaldin Ahmed
info@bluetechgt.com

INDIA

Nireekshan Engineering Services
Jagan K
diving@nireekshan.in

NORTH - SOUTH AMERICA

Go Deep International
David Cassidy
david.cassidy@godeepintl.com

AUSTRALIA & NEW ZELAND

BML Benfield Marketing
Leon Benbaruk
leon.benbaruk@xtra.co.nz



Polyethylene Buoys

For cost-efficiency



Cost-saving and maintenance-free AtoN

Conventional steel buoys are relics from 19th century, from the times before internet and e-Navigation.

Handling and deployment of steel buoys require heavy and expensive (to use) buoy tender vessel.

Benefits of PE-buoys over steel buoys

- **Buoy tender vessel is not needed:** The buoy itself and the mooring are significantly lighter compared to steel buoy.
- **Sinker and chain are lighter:** Slim spar-shaped buoy with bigger draft is exposed to smaller drag force caused by the waves.
- **Less maintenance is required:** The motions of a spar-shaped buoy are restful resulting less wear and tear of the mooring.
- **Life span is longer:** Polyethylene does not corrode, the color stability is tested to last for 20-30 years.

1930

2018



Maybe it is time for rethinking?



SeaHow provides solutions

SeaHow's adaptative production process enables easy customization of the buoys. We can provide our Customers with the solution that fulfill their needs in the most efficient way.

Buoys can be equipped with any lantern, device or power source according to the customer specifications. As default the buoys have high performance radar reflector inside the buoy and retro-reflectors.

SeaHow's Smart Buoy concept combines the robust polyethylene buoy with monitoring sensors and mobile data transmission to collect real-time oceanographic data from the sea, on-line 24/7.

Most common SeaHow buoy types

Buoy type	Dry weight (kg)	Focal Plane (m)	Draft (m)	Diameter (mm)
Offshore Buoy VPU800	1080	4.0	6.5	800
Coastal Buoy VPU500	350	2.6	4.8	500
Coastal Buoy VPU500/800	410	2.5	3.0	500/800
Port Buoy VPU400	212	2.3	4.5	400
Marine Spar EJ225	67	2.5	4.6	225
Boating Spar VEP160/225	36	2.0	1.4	160/225
River Buoy VPC400/800	200	2.0	1.5	400/800
Ice Buoy Maxi PV800	1192	4.0	6.2	800
Ice Buoy Medium SVV500	754	3.5	6.6	500



We can customize the buoys for your needs.

Experience and expertise

Polyethylene spar buoys have been produced and used in Finland since 1976. Even today 30.000 units of SeaHow polyethylene buoys of different type are in use year-round, including winter time.

The buoys meet all the recommendations set by the IALA . The buoys are made of High Density HD100 extruded polyethylene pipe that makes them significantly stronger than rotation moulded buoys.

Highly experienced personnel, the latest machinery and constant development together with ISO certified production guarantee high quality products for the benefit of our customers.



Smart Buoy Concept

More than just an AtoN



The buoy of future with smart features

Conventional Aids to Navigation are history, relics from the times before internet and e-Navigation. The general tendency for Internet of Things will change the navigational marking as well.

Smart Buoy is connected to network and capable for interactivity. The idea is to encapsulate electronic devices inside the buoy body without external components being exposed to damages.

The robust and stabile polyethylene body can be deployed offshore. The production process of the buoy is adaptive and enables easy customization for various kind of device configuration.

The buoy can be used for many applications, like 1) land based AtoN management, 2) on-line monitoring of oceanographic data, 3) radio link for data transfer and 4) offshore location reference.

Monitored data is transmitted to cloud-based SeaHow central system by available network. Optionally the data can also be delivered to Customer's own system.

Area of use

- Remote AtoN management
- Offshore monitoring station
- Remote ROV operations
- Unmanned ship systems
- Sulfur Sniffers



Smart Buoys



Real-time data for Mariners

Oceanographic data on bridge enhances safety of navigation. Smart Buoys used along the fairway can provide critical navigation data continuously.

IMO 2020 global sulfur limit and ECAS might require Smart Sniffer buoys. The future of Unmanned Ships most likely will require smart fairways.

Remote AtoN management

Smart Buoys save maintenance costs. The lights can be turned on or the intensity can be increased from ashore or remotely by the Pilots whenever needed.

Via SeaDatics software 1) the lantern can be adjusted 2) the buoy location monitored on-line and 3) an notification received in case of malfunction.

Remote ROV-operation

Remote ROV-operation require a radio-link solution that is easy to deploy and can tolerate rough handling without external parts exposed for damages.

Because of the robust monolite structure and excellent stability in high seas the SeaHow Smart Buoy is ideal solution for an offshore Radio-link station.

Environmental monitoring

For the protection of sensitive marine environment accurate and dynamic up-to-date data is essential and requires regular monitoring.

On-site monitoring can start from pre-construction through all the phases of a construction project and continuing to post project monitoring as required.

We can produce a buoy adaptable for almost any sensor

Default sensors available for monitoring

Parameter	Sensor	Range	Resolution	Accuracy
Temperature	YSI	-5..+50°C	0.01°C	+0.15°C
Conductivity	YSI	0..100 mS/cm	0.001 mS/cm	+0.5%
Salinity	YSI	0..70 ppt	0.01 ppt	+/-1%
Dissolved Oxygen	YSI	0..50 mg/l	0.01 mg/l	+/-2%
Turbidity	YSI	0..1000 NTU	0.1 NTU	+/-2% or 0.3 NTU
Algae chl-a	YSI	0..400 µg/l	0.1 µg/l	-
Algae Cyanobacterial	YSI	0..280 000 cells/ml	1 cell/ml	-
Height of Tide	Aanderaa	0..20 m	<0.0001%	+/-0.02%
Wave height	Aanderaa	0..20 m	<0.0001%	+/-0.02%
Current speed	Aanderaa	0..300 cm/s	0.1 %	1% or +/-0.15 cm/s
Current direction	Aanderaa	0..360°	+/-0.35°	+/-5°
Oil Spill - Crude	Turner	1-1500 ppb	1 ppb	-
Oil Spill - Fine	Turner	3-3500 ppb	1 ppb	-

Offshore Buoy

VPU800

SeaHow[®]
by MeriTaito

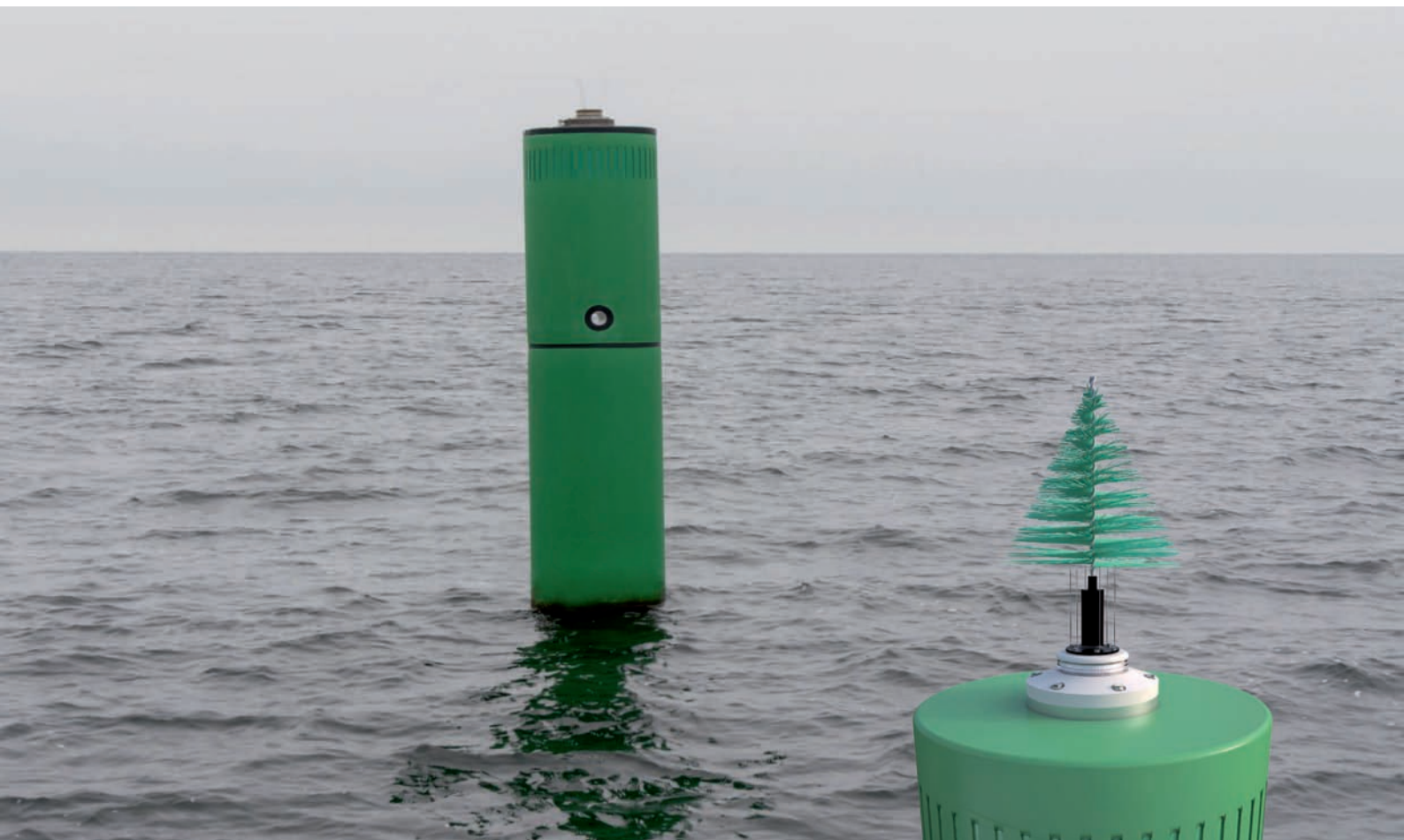

Designed and tested for high seas

Offshore Buoy VPU800 has proven track record of excellent performance in offshore locations. It provides robustness and conspicuity that is equal to conventional steel buoys, but much more maintenance-free years.

VPU800 is deployed in conventional way by using sinker and heavy slack chain. The movements of the buoy are calm even during high sea. This is because the buoy has excellent stability due to the high metacentric height (GM).

The storm and ice tolerance is superior compared to conventional shaped buoys. The slim body shape and semi-submerged structure exposes the buoy to less force caused by the waves or drifting ice.

The buoy can be equipped with any lantern in the market, self-contained or battery operated. Additional instrumentation and sensors of any kind can be encapsulated inside the buoy body.

Area of use

Offshore with high sea
Rough arctic sea areas
Smart Buoy solutions
Platform for various use

Specifications

*) can be adjusted according to customer needs

Overall length *)	10.9 m	Retro-reflector	380 cm ² (3M diamond)
Diameter	800 mm	Radar reflector	Trihedral TH800
Draft *)	6.9 m	Radar cross area	130 m ² (X-band)
Wall thickness	30 mm	Surface color	IALA-E108
Polyethylene material	HD 100 extruded pipe	Color and UV stability	26 years (lat. 50)
Polystyrene filling	EPS 150 closed shell	Mooring sinker weight	5 - 7 ton
Dry weight without ballast	1080 kg	Maximum current	2 kn
Required ballast weight *)	420 kg	Maximum wave height	8 m (significant)
Buoyancy at MSL	1500 kg	Lantern *)	Sabik as default
Focal plane at MSL *)	4.0 m	Battery capacity *)	220 or 1000 Ah
Nautical conspicuity	4 NM	Top Mark	Optional

We can customize the buoys for your needs

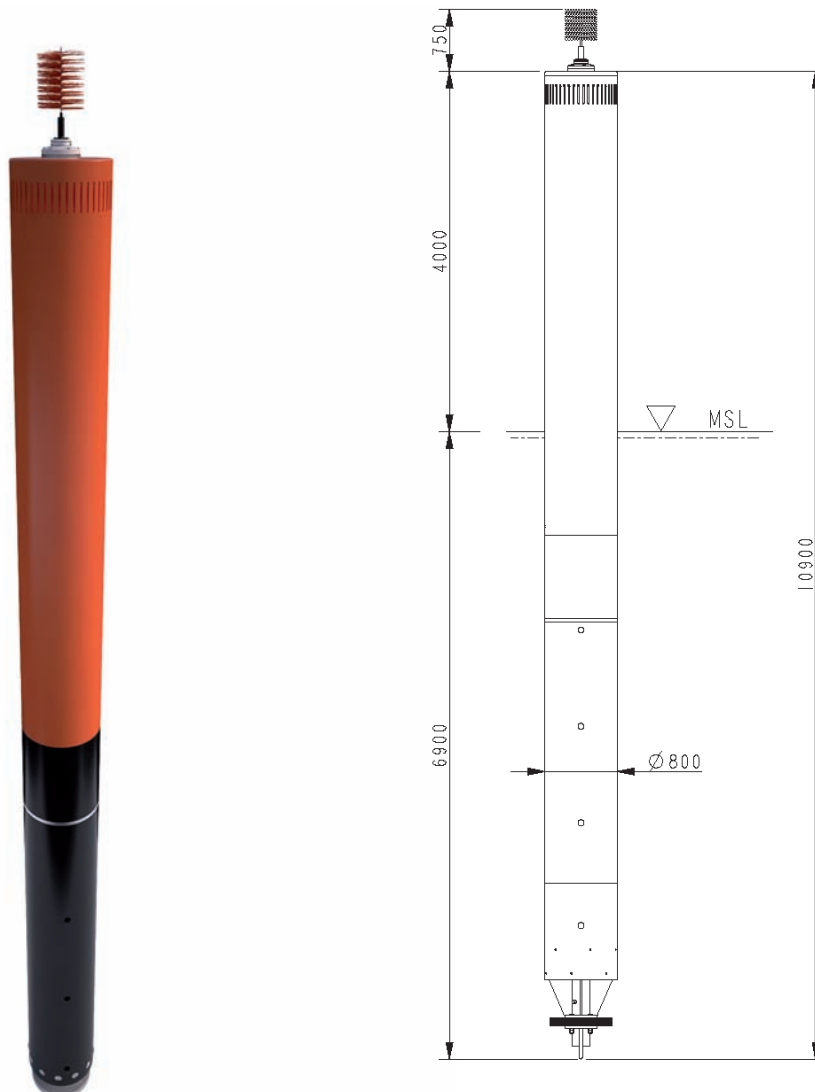

Coastal Buoy

VPU500

SeaHow[®]
by MeriTaito



Navigation buoy with long life span

Coastal Buoy VPU500 is economically feasible navigation buoy. It provides durability and conspicuity that is equal to many steel buoys of similar size, but much more maintenance-free years.

VPU500 is deployed in conventional way by using sinker and slack chain. The movements of the buoy are calm even in high sea. This is because the buoy has excellent stability due to the high metacentric height (GM).

The storm and ice tolerance is superior compared to conventional shaped buoys. The slim body shape and semi-submerged structure exposes the buoy to less force caused by the waves or drifting ice.

The buoy can be equipped with any lantern in the market, self-contained or battery operated. Additional instrumentation and sensors of many kinds can be encapsulated inside the buoy body.



Area of use

Coastal and open sea
Ice covered sea areas
Smart Buoy solutions
Platform for various use

Specifications

*) can be adjusted according to customer needs

Overall length *)	7.4 m	Retro-reflector	380 cm ² (3M diamond)
Diameter	500 mm	Radar reflector	Trihedral TH500
Draft *)	4.8 m	Radar cross area	20 m ² (X-band)
Wall thickness	20 mm	Surface color	IALA-E108
Polyethylene material	HD 100 extruded pipe	Color and UV stability	26 years (lat. 50)
Polystyrene filling	EPS 150 closed shell	Mooring sinker weight	4 - 6 ton
Dry weight without ballast	350 kg	Maximum current	2 kn
Required ballast weight *)	260 kg	Maximum wave height	4 m significant
Buoyancy at MSL	610 kg	Lantern *)	Sabik as standard
Focal plane at MSL *)	2.6 m	Battery capacity	220 Ah
Nautical conspicuity	3 NM	Top Mark	Optional

We can customize the buoys for your needs

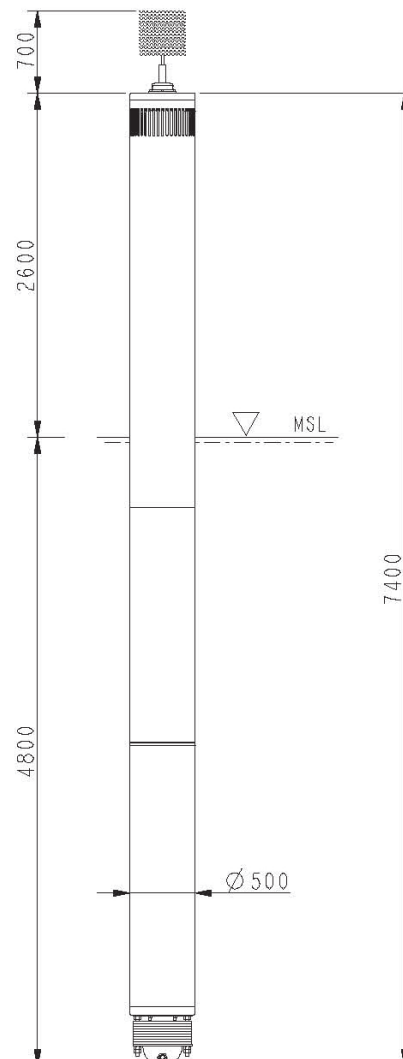

Coastal Buoy Shallow

VPU500/800

SeaHow[®]
by MeriTaito



Navigation buoy with long life span

Coastal Buoy Shallow VPU500/800 is economically feasible navigation buoy with small draft and features that are equal to many steel buoys of similar size, but much more maintenance-free years.

VPU500/800 is designed for year-round use including high sea and ice covered areas. The moderate length and weight of the buoy enables easy handling.

The buoy is deployed in conventional way by sinker and slack chain. Using the side mooring eye enables the use in waters with current up to 4 knots and still have tilting less than 10 degrees.

The buoy can be equipped with any lantern in the market, self-contained or battery operated. Additional instrumentation and sensors of many kinds can be encapsulated inside the buoy body.

Area of use

Coastal and open sea
Ice covered sea areas
Areas with current
Platform for various use

Specifications

*) can be adjusted according to customer needs

Overall length *)	5.5 m	Retro Reflector	380 cm ² (3M diamond)
Diameter	500/800 mm	Radar Reflector	Trihedral TH500
Draft *)	3.0 m	Radar cross area RCS	20 m ² (X-band)
Wall thickness	20/30 mm	Surface color	IALA-E108
Polyethylene material	HD 100 extruded pipe	Color and UV stability	26 years (lat. 50)
Polystyrene filling	EPS 150 closed shell	Mooring sinker weight	4 - 6 ton
Dry weight without ballast	410 kg	Maximum current	4 kn/10 deg tilting
Required ballast weight	150 kg	Maximum wave height	5 m (significant)
Buoyancy at MSL	660 kg	Lantern *)	Sabik as default
Focal plane at MSL *)	2.5 m	Battery Capacity *)	220 Ah
Nautical conspicuity	3 NM	Top Mark	Optional

We can customize the buoys for your needs

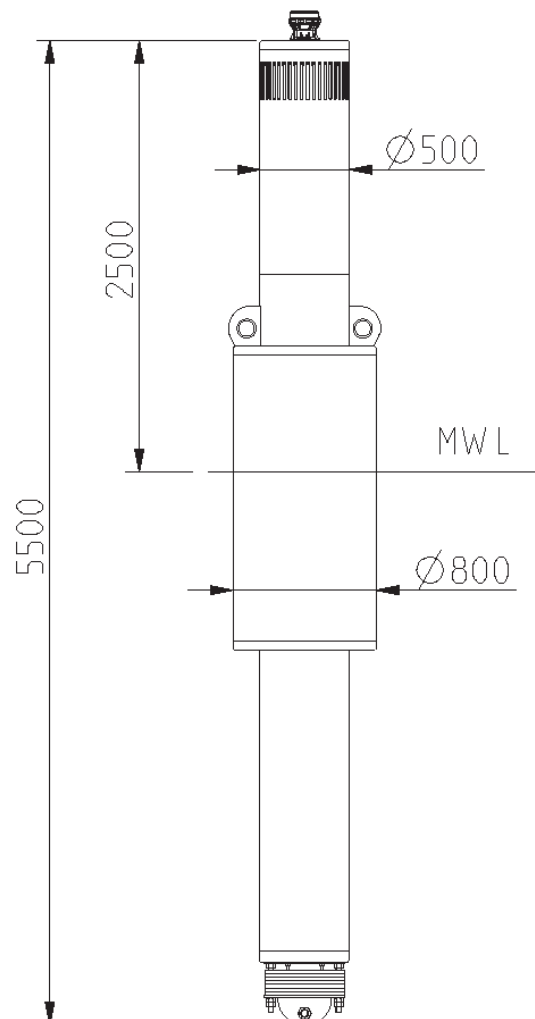

Port Buoy

VPU400

SeaHow[®]
by MeriTaito



Conspicuity and quality for competitive price

Port Buoy VPU400 is ideal marker buoy for short to medium range with competitive price-quality ratio. It provides conspicuity that is adequate to many locations in ports and coastal areas.

VPU400 is deployed in conventional way by using sinker and slack chain. The high performance radar reflector inside, effective retro-reflector and bright colors make it easy to detect.

The buoy has optimal features to be used in Ports. Possible collisions with vessels will not damage either. This is due to hit-tolerant elastic body and relatively light weight of the buoy.

The buoy can be equipped with any lantern with less than 4 kg in weight.



Area of use

Ports and Marinas
Fish and Wind farms
Inland waterways
Traffic sign floats

Specifications

*) can be adjusted according to customer needs

Overall length *)	6.8 m	Retro-reflector	330 cm ² (3M diamond)
Diameter	400 mm	Radar reflector	Trihedral TH400
Draft *)	4.5 m	Radar cross area RCS	3.4 m ² (X-band)
Wall thickness	15 mm	Surface color	IALA-E108
Polyethylene material	HD 100 extruded pipe	Color and UV stability	26 years (lat. 50)
Polystyrene filling	EPS 150 closed shell	Mooring sinker weight	6 - 8 ton
Dry weight without ballast	212 kg	Maximum current *)	2 kn
Required ballast weight *)	150 kg	Maximum wave height	3 m (significant)
Buoyancy at MSL	362 kg	Lantern *)	Sabik as default
Focal plane at MSL *)	2.3 m	Battery capacity	220 Ah
Nautical conspicuity	2 NM	Top Mark	Optional

We can customize the buoys for your needs

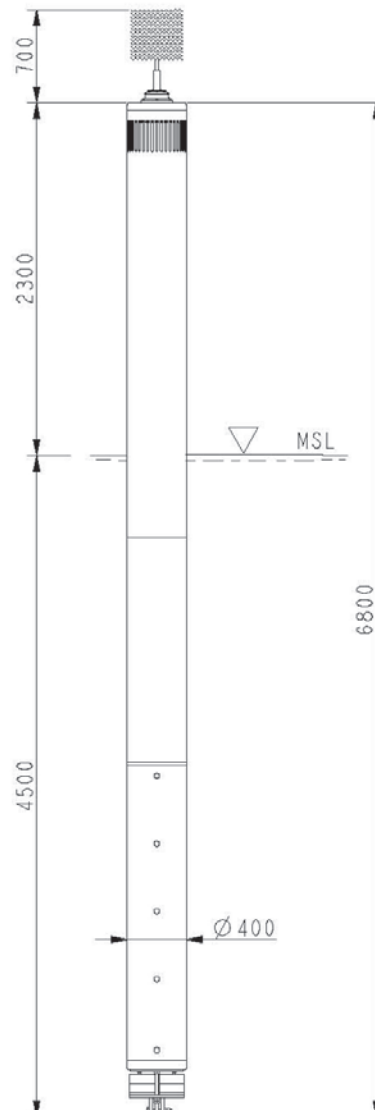

Marine Spar

EJV225

SeaHow[®]
by MeriTaito



Economical marker for year-round use

Marine Spar EJV225 has successful history of 40 years. Even today 7000 units in year-round service in the Finnish ice covered waters is a proof of durability that is hard to beat.

Bright colors, retro-reflectors and high performance radar reflector, diameter of 225 mm and focal plane of 2,5 m provide functionality that is superior to conventional buoys in this price category.

EJV225 is moored with taut chain which gives superior accuracy for the buoy location. Taut mooring is also advantageous when considering the survival among the ice.

Normally the buoy comes without lantern, but it can be equipped with a self-contained lantern with less than 2 kg in weight.



Area of use

Ports and Marinas
Border marking
Fish and Wind farms
Narrow waterways

Specifications

*) can be adjusted according to customer needs

Overall length *)	7.1 m	Light reflector	127 cm ² (3M diamond)
Diameter	225 mm	Radar reflector	Trihedral TH225
Draft *)	4.6 m	Radar cross area RCS	9.2 m ² (X-band)
Wall thickness	9 mm	Surface color	IALA-E108
Polyethylene material	HD 100 extruded pipe	Color and UV stability	26 years (lat. 50)
Polystyrene filling	EPS 150 closed shell	Mooring sinker weight	1 - 2 ton
Dry weight without ballast	67 kg	Maximum current	1 kn
Chain load at MSL	115 kg	Maximum wave height	2 m (significant)
Buoyancy at MSL	182 kg	Lantern *)	Carmanagh as default
Focal plane at MSL *)	2,5 m	Battery capacity	N/A
Nautical conspicuity	1 NM	Top Mark	Optional

We can customize the buoys for your needs

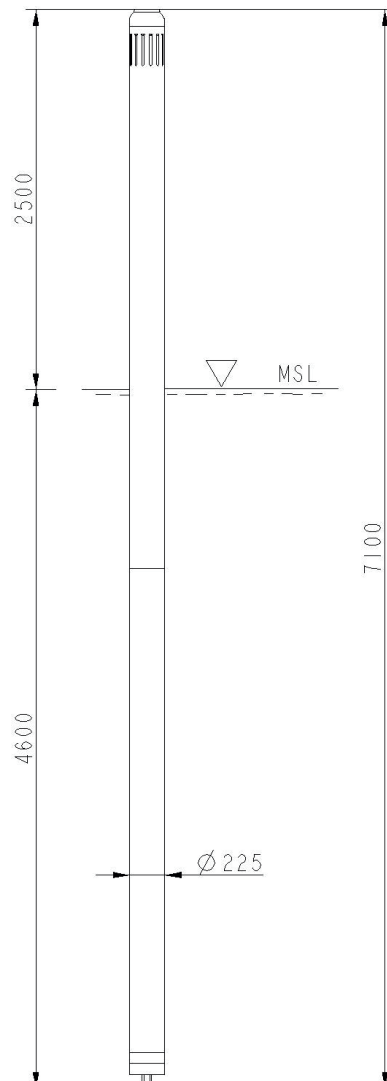

Boating Spar

VEP160/225

SeaHow[®]
by MeriTaito



Optimal buoy for Marinas

Boating Spar VEP160/225 is designed for Marinas and shallow waters and has a draft of only 1,4 m. Even today 5000 units are in year-round use in Finland.

The buoy has optimal features to be used in Marinas. Conspicuity is adequate and possible collisions with boats will not damage either. This is due to hit-tolerant elastic body and light weight of the buoy.

VEP160/225 is deployed in conventional way by using sinker and rope. Due to relatively small buoyancy chain cannot be used.

The buoy is used without a lantern.



Area of use

Marinas
Boating fairways
Inland waterways
Marker buoys

Specifications

*) can be adjusted according to customer needs

Overall length *)	3.4 m	Retro reflector	72 cm ² (3M diamond)
Diameter	160/225 mm	Radar reflector	Trihedral TH160
Draft *)	1.4 m	Radar cross area RCS	9.2 m ² (X-band)
Wall thickness	6.3 mm	Color	IALA-E108
Polyethylene material	HD 100 extruded pipe	Color and UV stability	26 years (lat. 50)
Polystyrene filling	EPS 150 closed shell	Mooring sinker weight	0.6 - 1.0 ton
Dry weight without ballast	36 kg	Maximum current	1 kn
Required ballast weight	12 kg	Maximum wave height	1 m (significant)
Buoyancy at MSL	48 kg	Lantern	N / A
Focal plane at MSL *)	2.0 m	Battery capacity	N / A
Nautical conspicuity	0.5 NM	Top Mark	Optional

We can customize the buoys for your needs

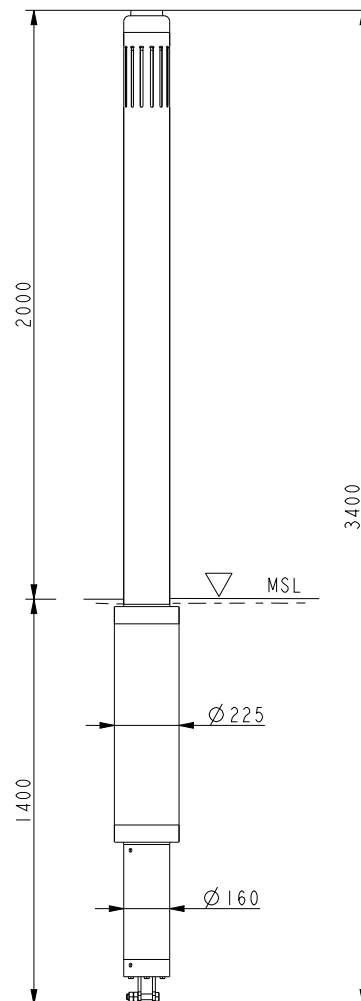

River Buoy

VPC400/800

SeaHow[®]
by MeriTaito



Optimization through mathematical modeling

River Buoy VPC400/800 is specially designed to be used as navigation buoy in rivers and coastal areas with heavy current. Tilting remains less than 10 degrees even in the current of 4 knots.

VPC400/800 has optimal features to be used in river channels. Possible collisions with vessels will not damage either. This is due to hit-tolerant elastic body and relatively light weight of the buoy.

The buoy is deployed in conventional way by sinker, slack chain and side mooring eye. The high performance radar reflector inside, effective retro-reflector and bright colors make it easy to detect.

The buoy can be equipped with any lantern with less than 4 kg in weight.



Area of use

River channels
Areas with tidal current
Estuaries

Specifications

*) can be adjusted according to customer needs

Overall length *)	3.5 m	Retro reflector	330 cm ² (3M diamond)
Diameter	400/800 mm	Radar reflector	Trihedral TH400
Draft *)	1.5 m	Radar cross area RCS	3.4 m ² (X-band)
Wall thickness	15/30 mm	Surface color	IALA-E108
Polyethylene material	HD 100 extruded pipe	Color and UV stability	26 years (lat. 50)
Polystyrene filling	EPS 150 closed shell	Mooring sinker weight	2 - 4 ton
Dry weight without ballast	200 kg	Maximum current	4 kn/10 deg tilting
Required ballast weight	126 kg	Maximum wave height	2 m (significant)
Buoyancy at MSL	326 kg	Lantern *)	Sabik as default
Focal plane at MSL *)	2.0 m	Battery capacity *)	220 Ah
Nautical conspicuity	2 NM	Top Mark	Optional

We can customize the buoys for your needs

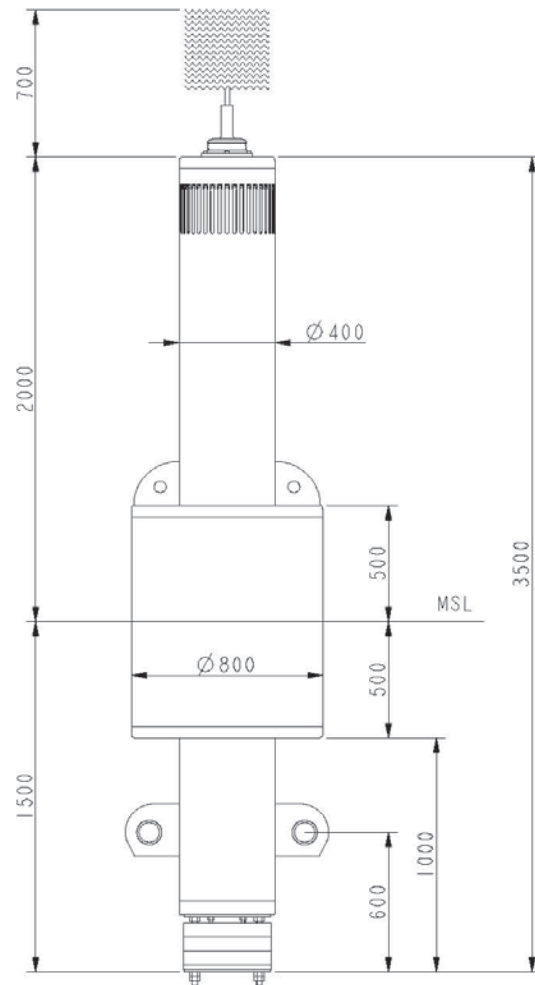

Ice Buoy Maxi

PV800

SeaHow[®]
by MeriTaito



The only ice proof tested buoy in the market

Ice Buoy Maxi PV800 has proven track record of successfully being used in arctic areas. It provides robustness and conspicuity that is equal to conventional steel buoys, but much more maintenance-free years.

PV800 is normally moored with taut chain which gives superior accuracy for the buoy location. Taut mooring is also advantageous when considering the survival among the ice.

The buoy can be equipped with any ice lantern and primary battery in the market. Additional instrumentation and sensors of any kind can be encapsulated inside the buoy body.

For tidal areas we recommend the use of Offshore Buoy VPU800 which is similar type of buoy but deployed conventionally with slack chain.



Area of use

Rough arctic sea areas
Narrow channels
Smart Buoy solutions
Platform for various use

Specifications

*) can be adjusted according to customer needs

Overall length *)	10.2 m	Retro-reflector	380 cm ² (3M diamond)
Diameter	800 mm	Radar reflector	Trihedral TH800
Draft *)	6.2 m	Radar cross area RCS	124 m ² (X-band)
Wall thickness	30 mm	Surface color	IALA-E108
Polyethylene material	HD 100 extruded pipe	Color and UV stability	26 years (lat. 50)
Polystyrene filling	EPS 150 closed shell	Mooring sinker weight	10 - 15 ton
Dry weight without ballast	1192 kg	Maximum current	2 kn
Chain load at MSL	1454 kg	Maximum wave height	6 m (significant)
Buoyancy at MSL	2646 kg	Lantern *)	Sabik as default
Focal plane at MSL *)	4.0 m	Battery capacity *)	220 or 1000 Ah
Nautical conspicuity	4 NM	Top Mark	Optional

We can customize the buoys for your needs

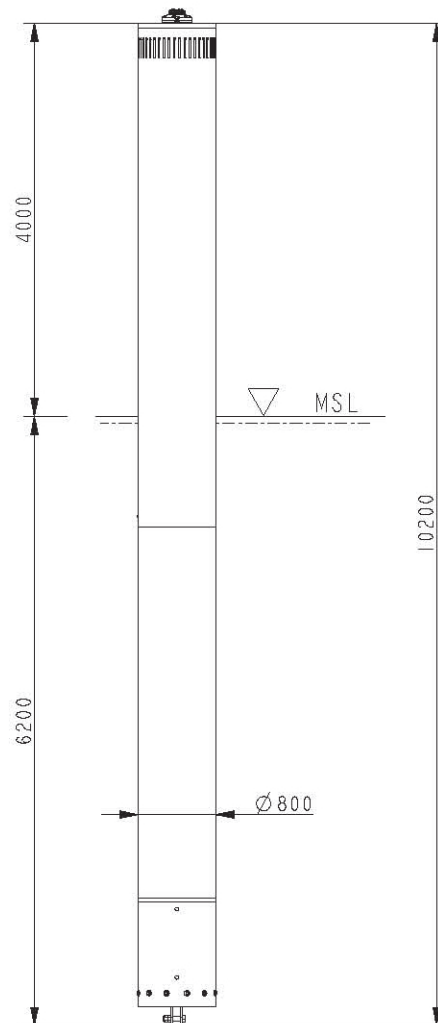

Ice Buoy Medium

SVV500

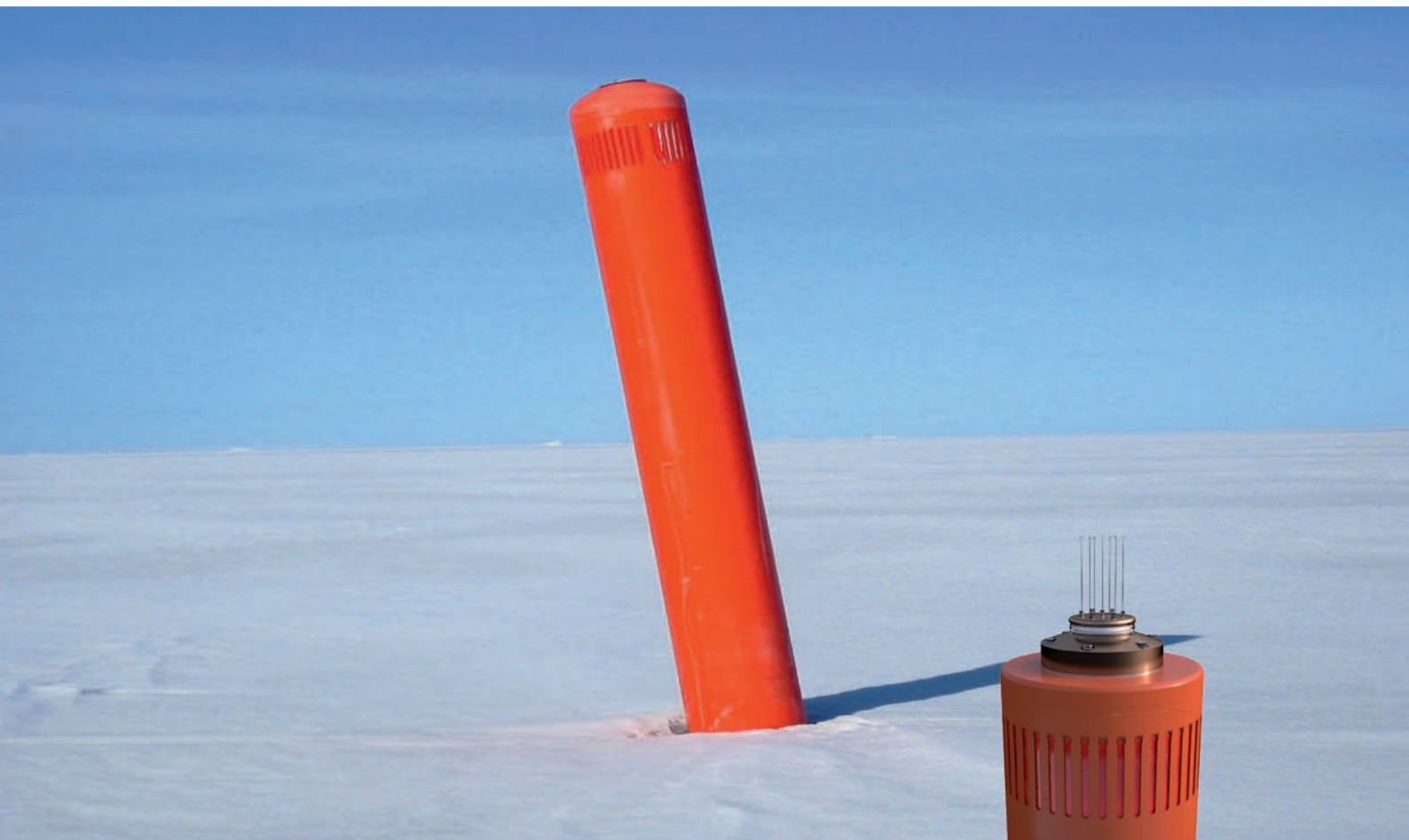

Robustness and conspicuity for ice covered areas

Ice Buoy Medium SVV500 is economically feasible buoy for use in ice covered areas. It provides durability that is equal to many steel buoys of similar size, but much more maintenance-free years.

SVV500 is normally moored with taut chain which gives superior accuracy for the buoy location. Taut mooring is also advantageous when considering the survival among the ice.

The buoy can be equipped with any lantern in the market, self-contained or battery operated. Additional instrumentation and sensors of many kinds can be encapsulated inside the buoy body.

For tidal areas we recommend the use of Coastal Buoy VPU500 which is similar type of buoy but deployed conventionally with slack chain.

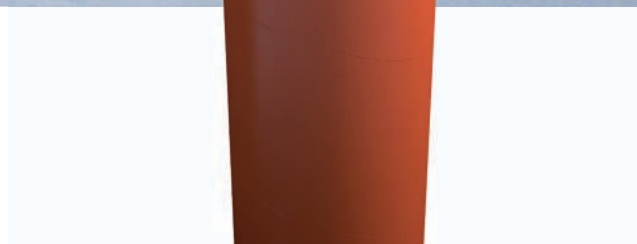

Area of use

Ice covered areas
Narrow channels
Smart Buoy solutions
Platform for various use

Specifications

*) can be adjusted according to customer needs

Overall length *)	10.15 m	Retro-reflector	380 cm ² (3M diamond)
Diameter	500 mm	Radar reflector	Trihedral TH500
Draft *)	6.55 m	Radar cross area RCS	20 m ² (X-band)
Wall thickness	30 mm	Surface color	IALA-E108
Polyethylene material	HD 100 extruded pipe	Color and UV stability	26 years (lat. 50)
Polystyrene filling	EPS 150 closed shell	Mooring sinker weight	6 - 8 ton
Dry weight without ballast	754 kg	Maximum current	2 kn
Chain load at MSL	502 kg	Maximum wave height	4 m (significant)
Buoyancy at MSL	1256 kg	Lantern *)	Sabik as default
Focal plane at MSL *)	3.5 m	Battery capacity	220 Ah
Nautical conspicuity	3 NM	Top Mark	Optional

We can customize the buoys for your needs

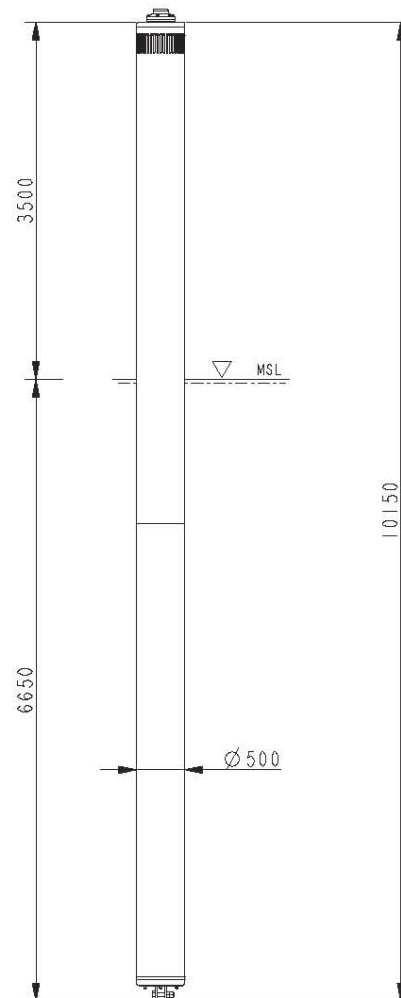

Beacon Tower

TM 500/TM 800



Combined daymark & radar target & beacon

Beacon Tower TM800 or TM500 has triple functionality. Besides being the superstructure for the light it also provides daymark with superior conspicuity and efficient radar response. It is ideal solution to replace old beacons or small lighthouses.

The daytime conspicuity enhances the safety of Navigation especially in areas with few natural land marks, like archipelago or arctic environment in winter time when all of the landscape tend to look alike.

Beacon Tower is made from polyethylene and requires only minimum maintenance. The light weight, modular structure and easy foundation enable fast erection with moderate size of equipment. Foundation design comes along with the tower.

The construction utilizes SeaHow's proven spar-buoy technology using high quality materials and encapsulating the components inside the tower body. The tower can be equipped with any marine lantern and different kinds of power sources.

Benefits

- Excellent optical conspicuity
- Improved radar response
- Easy transport and installation
- Low maintenance need

Specifications	TM 500	TM 800
Overall length *)	2.4, 3.6, 4.8 m	4.8, 6.0, 7.5, 9.0 m
Diameter	500 mm	800 mm
Wall thickness	30mm	30 mm
Polyethylene material	HD 100 extruded pipe	HD 100 extruded pipe
Weight	180 - 290 kg	480 - 780 kg
Retro-reflector	3M diamond	3M diamond
Radar reflector	TH500	TH800
Radar cross area RCS	20 m ²	130 m ²
Color IALA-108 *)	Yellow-red-yellow	Yellow-red-yellow
Color durability	26 years (lat. 50)	26 years (lat. 50)
Optional accessories *)		
Marine lanterns	Yes (Sabik as default)	Yes (Sabik as default)
Solar panel	Yes	Yes
Ladder	Yes	Yes
Rack for Devices	Yes	Yes

*) can be adjusted according to customer needs

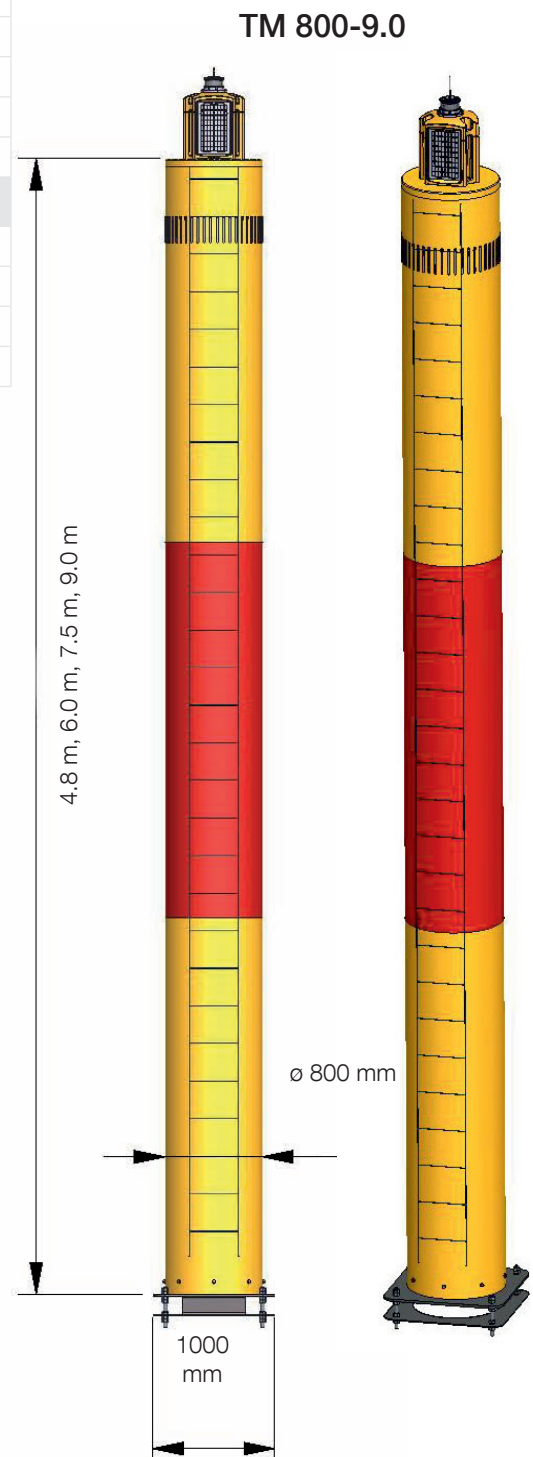
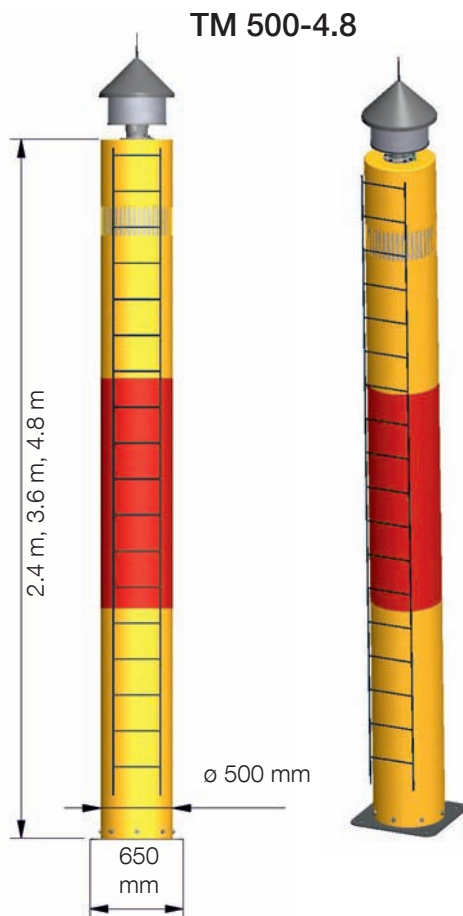



SeaHow[®]
by MeriTaito

Meritaito Ltd - SeaHow
P.O. Box 111, (Porkkalankatu 5)
FI-00181 Helsinki, Finland
Tel. +358 40 823 2122
info@seahow.fi • www.seahow.fi



SeaHow[®]
by MeriTaito

Meritaito Ltd - SeaHow
P.O. Box 111, (Porkkalankatu 5)
FI-00181 Helsinki, Finland
Tel. +358 40 823 2122
info@seahow.fi • www.seahow.fi